

INTREPID™ POE SYSTEM CONTROLLERS

IP-BASED POWER OVER ETHERNET (POE) PERIMETER CONTROL OPTIONS



INTREPID™ POE System Controllers provide flexible perimeter security management options for Southwest Microwave's IP-based POE detection technologies, enabling the development of an alarm monitoring and control program to suit a facility's unique requirements. INTREPID™ POE controllers offer scalable, plug-and-play solutions to manage sites of any size or configuration, with features ranging from local or remote relay control to centralized TCP / IP-based management of large or multi-site applications.

INTREPID™ POE controllers conveniently and reliably manage INTREPID™ POE perimeter detection sensors, including Model 316-POE and Model 336-POE Digital Microwave Links. These controllers enable the assignment of alarm inputs to specific perimeter zones. Zones may be visually depicted on a graphic user interface (GUI) and / or trigger outputs such as relay closures and camera PTZ presets so that when a perimeter breach is detected, precise visual assessment is achieved.

INTREPID™ POE controllers seamlessly integrate INTREPID™ POE devices via TCP / IP network communications protocol using a standard Ethernet connection. Control modules also manage auxiliary security devices and interface with assessment equipment (CCTV / NVR) or other system outputs.

An INTREPID™ POE Software Development Kit (SDK) is available to developers at no cost for high-level interface of INTREPID™ POE sensors into custom monitoring and control applications.

Contact us at infosd@southwestmicrowave.com or +1 (480) 783-0201 for further information or to request INTREPID™ SDK documentation.



Perimeter Security Manager II (PSM II)



Control Module-POE



INTREPID™ POE
Software Development Kit (SDK)

PERIMETER SECURITY MANAGER II (PSM II)

Perimeter Security Manager II (PSM II) is an advanced, Windows®-based security monitoring and control application that provides powerful intrusion detection system management capabilities and ease of use. The system is ideal for users seeking to manage numerous perimeter security devices and visual assessment tools across single or multiple networked locations.

PSM II monitors, displays and controls Southwest Microwave's range of intelligent perimeter detection systems, including INTREPID™ Series II devices (MicroPoint™ II, MicroNet™ II, MicroTrack™ II, MicroWave 330) and POE sensors (Model 336-POE and Model 316-POE). The system also seamlessly manages contact-closure auxiliary security devices, and facilitates high-level interface to CCTV cameras, digital or network video recorders and monitors.



Refer to Southwest Microwave's Perimeter Security Manager II data sheet for complete details and features.

KEY FEATURES

- SEAMLESS INTEGRATION OF SECURITY DEVICES AND CAMERAS
- INTUITIVE, ICON-BASED GUI WITH OPTIONAL TOUCH-SCREEN CONTROLS
- SECURE, 256-BIT AES ENCRYPTION AND TRANSPORT LAYER SECURITY (TLS)
- FLEXIBLE DISPLAY OF LIVE VIDEO AND HIGH-RESOLUTION GRAPHIC MAPS
- PATENTED MIGRATING 3+ REDUNDANCY
- CUSTOMIZABLE SCREENS AND EVENT-HANDLING PROCESSES
- SCALABLE, WINDOWS®-BASED TCP/IP ARCHITECTURE
- EASY SITE NAVIGATION VIA CUSTOMIZABLE 'PORTALS'

CONTROL MODULE-POE (CM-POE)

The CM-POE is a System Controller designed to provide midsized facilities with robust local or remote control of INTREPID™ POE sensors, contact-closure auxiliary security devices and CCTV monitoring equipment. It is supplied as a self-contained module and features intuitive, software-based system configuration, zone assignment and management. The CM-POE features built-in POE and TCP/IP network communications for local or remote sensor configuration and alarm monitoring.



The CM-POE functions as Pollmaster, polling all INTREPID™ POE devices discovered on its network for status. When an intrusion attempt is detected from any INTREPID™ device or auxiliary input, a command is issued to the appropriate local relay output(s).

KEY FEATURES

- IP-BASED WITH BUILT-IN POE
- FULLY HARDENED DESIGN
- INTUITIVE ON-BOARD SET-UP SOFTWARE
- BUILT-IN WEB SERVER
- 16 ON-BOARD RELAYS TO DELIVER CRITICAL MESSAGES
- CONNECTS UP TO 32 INTREPID™ DEVICES
- SUPPORTS 128 ZONES (4IN / 4OUT)
- LOCAL OR REMOTE ADMINISTRATION AND ALARM MONITORING
- EVENT LOG & CONFIGURATION REPORTS

INTREPID™ POE SOFTWARE DEVELOPMENT KIT (SDK)

Software Development Kit (SDK) is available at no-cost to developers for high-level integration between INTREPID™ POE detection sensors and custom monitoring and control applications. This flexible control option enables interface between a user's preferred VMS or PSIM application and INTREPID™ POE sensors and auxiliary devices.



The INTREPID™ Polling Protocol II (IPP II) standard, developed by Southwest Microwave, Inc., is an application layer protocol using packet/frame format that provides Master/Slave communications between third party control equipment and INTREPID™ POE sensors over an IP network.

Refer to Southwest Microwave's POE SDK development document for integration capabilities and development details.

POE SENSOR CONTROLLER AND DEVICE CONFIGURATION

Each INTREPID™ POE Sensor Controller can communicate with any combination of INTREPID™ POE devices via an open-architecture TCP/IP network communications protocol.

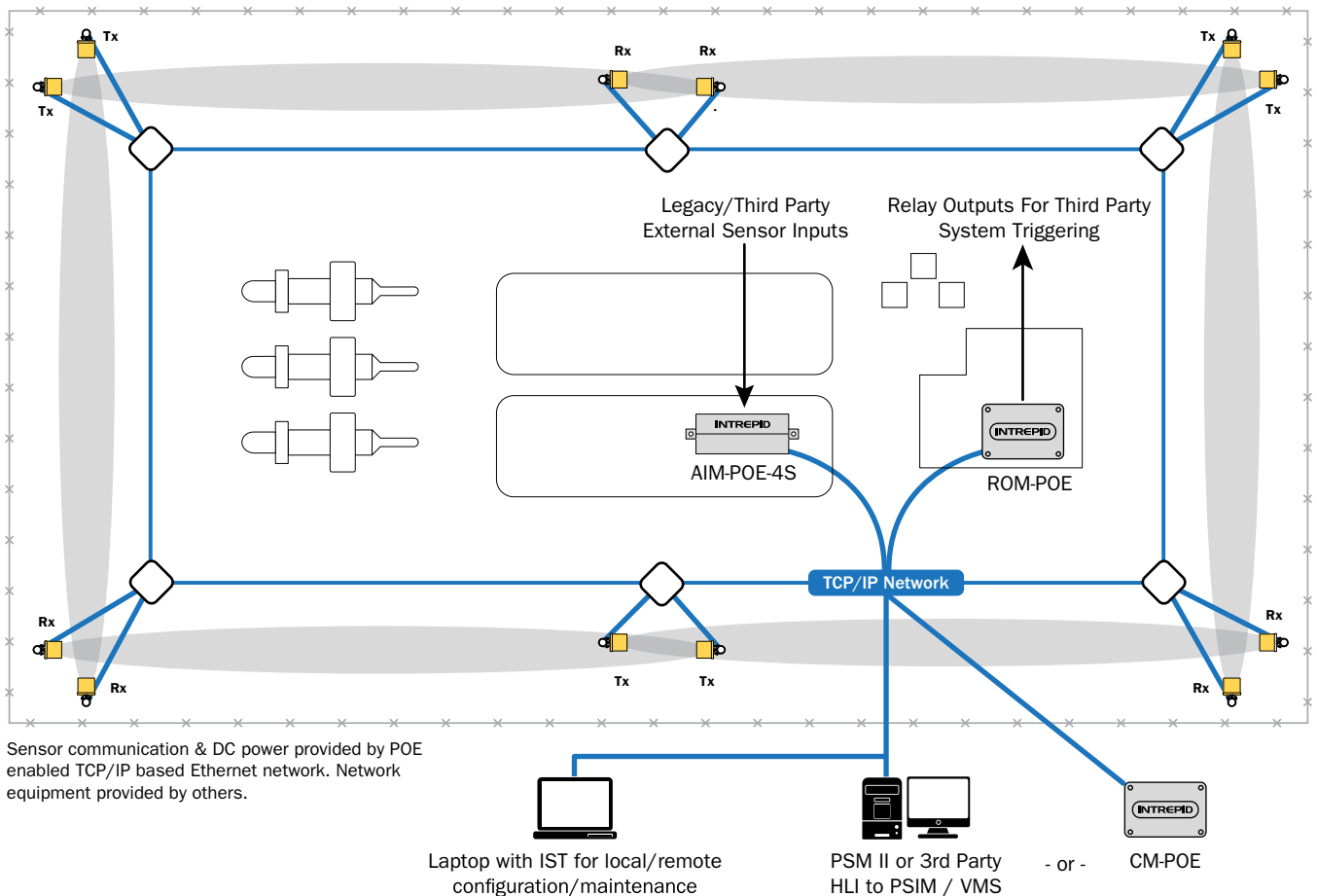
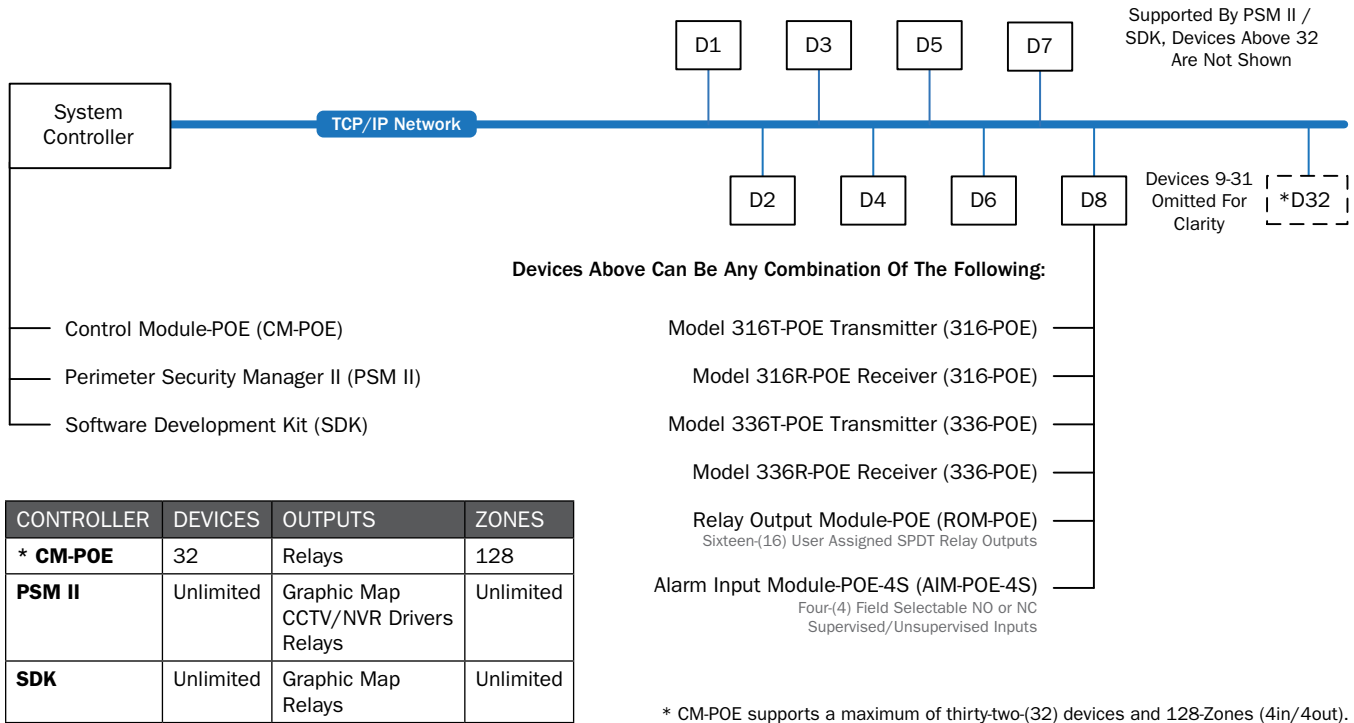

INTREPID™ POE SYSTEM CONTROLLERS SPECIFICATIONS

PERIMETER SECURITY MANAGER II (PSM II)

Refer to Perimeter Security Manager II data sheet for Specifications.

POE SOFTWARE DEVELOPMENT KIT (SDK)

INTREPID POE Communications: Refer to Southwest Microwave Document #57A47169-A01 for Specifications.

CONTROL MODULE-POE (CM-POE)

Size: 268 H x 333 W x 108 D mm (8.59 x 13.11 x 4.26 in)
Weight: 1.1 kg (2.5 lbs)
Operating Temperature: -40° C to 70° C (-40° F to 158° F)
POE: Power over Ethernet, IEEE 802.3af, Class 0
Power Requirements: 2.2 Watts typical
Ethernet: RJ-45 connector, 10/100 Base-T
Outputs: 16 fully sealed relays, SPDT (Form 1C). Conforms to FCC Part 68 requirements for coil to contacts (1,500 V, 10 x 160 µs)
Supported Browsers: Internet Explorer 11, Edge 40, Firefox 54, Chrome 59 or higher.

M2M Communications:

- Protocol: IPP over TCP, 2 connections
- SDK available

LED Indicators: Relay outputs

Languages: English

INTREPID™ POE INPUT / OUTPUT MODULES

The INTREPID™ Alarm Input Module-POE-4S (AIM-POE-4S) and Relay Output Module-POE (ROM-POE) are self-contained fully-hardened modules that provide simple interface to contact-closure controlled alarm inputs or relay outputs that do not communicate using the INTREPID™ POE communications protocol. Each module features user-friendly on-board set-up software.

Alarm Input Module-POE-4S (AIM-POE-4S): Allows the incorporation of auxiliary devices – such as Southwest Microwave’s conventional digital or analog microwave sensors, gate and door contacts or other alarm contacts. Provides 4 supervised contact-closure inputs.*

Relay Output Module-POE (ROM-POE): Provides simple local interface to CCTV equipment, legacy alarm panels, perimeter lighting or other relays. Provides 16 relay outputs.*

* An INTREPID™ POE System Controller such as CM-POE or PSM II is required to configure the inputs / outputs of the AIM-POE-4S and ROM-POE.

ALARM INPUT MODULE-POE-4S (AIM-POE-4S)

Size: 139 H x 337 W x 127 D mm (5.5 x 13.3 x 5 in)
Weight: 1.1 kg (2.5 lbs)
Operating Temperature: -40° C to 70° C (-40° F to 158° F)
POE: Power over Ethernet, IEEE 802.3af, Class 0
Power Requirements: 2.2 Watts typical
Ethernet: RJ-45 connector, 10/100 Base-T
Inputs: 4 field selectable NO or NC supervised / unsupervised inputs
DC Output: 12.0VDC, 400mA
Supported Browsers: Internet Explorer 11, Edge 40, Firefox 54, Chrome 59 or higher.

M2M Communications:

- Protocol: IPP over TCP, 2 connections
- SDK available

LED Indicators: Communication status, alarm, pulse

Languages: English

RELAY OUTPUT MODULE-POE (ROM-POE)

Size: 268 H x 333 W x 108 D mm (8.59 x 13.11 x 4.26 in)
Weight: 1.1 kg (2.5 lbs)
Operating Temperature: -40° C to 70° C (-40° F to 158° F)
POE: Power over Ethernet, IEEE 802.3af, Class 0
Power Requirements: 2.2 Watts typical
Ethernet: RJ-45 connector, 10/100 Base-T
Outputs: 16 fully sealed relays, SPDT (Form 1C). Conforms to FCC Part 68 requirements for coil to contacts (1,500 V, 10 x 160 µs)
Supported Browsers: Internet Explorer 11, Edge 40, Firefox 54, Chrome 59 or higher.

M2M Communications:

- Protocol: IPP over TCP, 2 connections
- SDK available

LED Indicators: Relay outputs

Languages: English



INTREPID™, MicroTrack™, MicroPoint™ and MicroNet™ are trademarks of Southwest Microwave, Inc. Windows® is a registered trademark of Microsoft Corporation. Specifications subject to change without notice.



USA (CORPORATE HEADQUARTERS): Southwest Microwave, Inc., Arizona, USA | Telephone +1 (480) 783-0201

EUROPEAN OFFICES: Southwest Microwave Ltd., Worcestershire, UK | Telephone +44 1386 75 15 11