

# INTREPID™

## SOFTWARE DEVELOPMENT KITS (SDK)

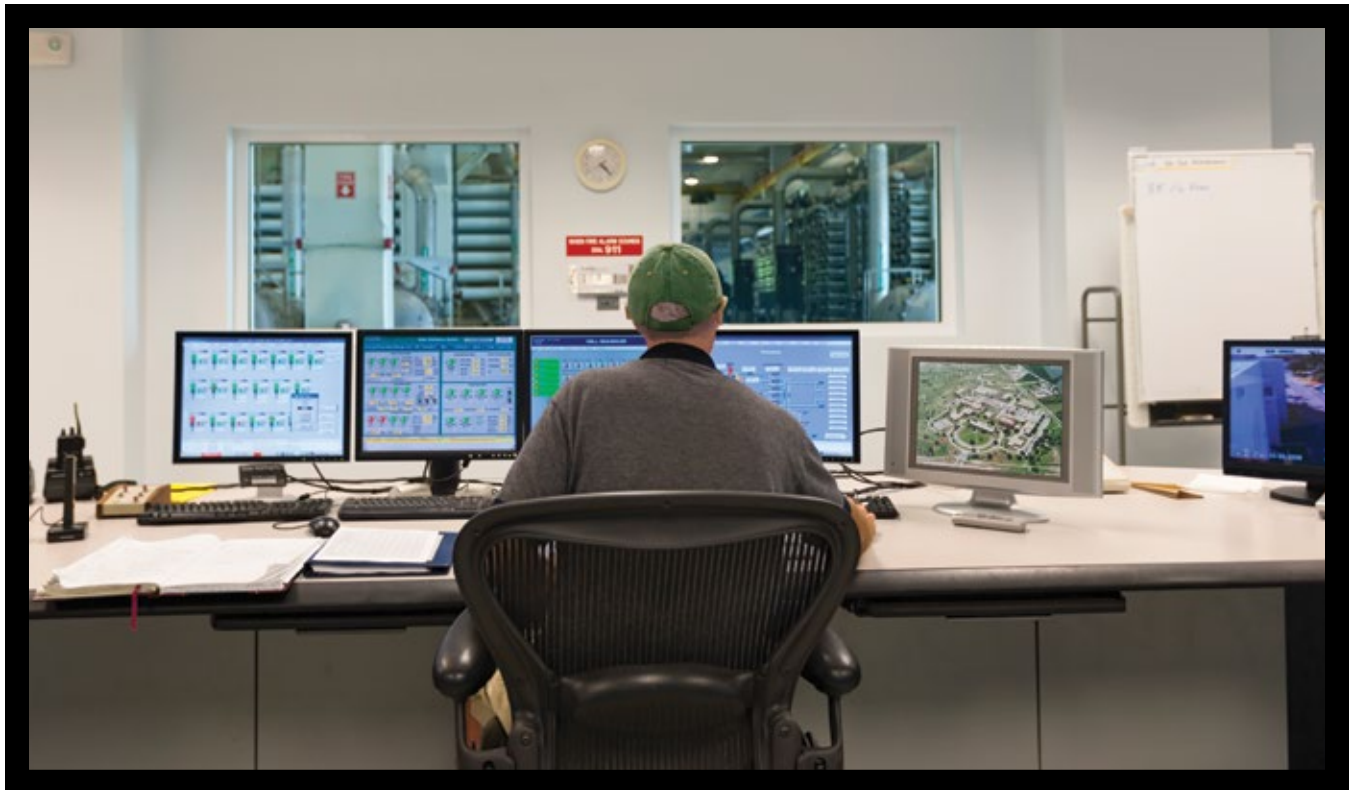

Remote Polling Module II (RPM II)



INTREPID™ Polling Protocol II (IPP II)

Southwest Microwave is committed to providing perimeter security solutions that will integrate seamlessly into our customers' overall security programs. We offer Software Development Kit (SDK) documentation to developers and systems integrators for INTREPID™ Series II perimeter intrusion detection systems (MicroPoint™ II, MicroTrack™ II, MicroWave 330) enabling discovery, monitoring, command and control of these technologies through new or existing physical security information management (PSIM) systems, assessment technologies (CCTV / DVR) and other custom control applications.

Southwest Microwave's SDK toolkits achieve a range of control and monitoring functionality\* for the INTREPID™ sensor suite and auxiliary inputs, including:

- Real-time notification of intrusion attempts, tamper and service alarms
- Monitoring of auxiliary inputs on all INTREPID™ devices for alarm and tamper conditions
- Tie-in of camera setting and position presets to fence, buried cable and microwave detection zones
- Visual assessment of intrusion attempts or tampering
- Storage of intrusion and tamper events in alarm history

With TCP/IP networks commonly used as a base for security and surveillance command and control applications, these SDK resources allow plug-and-play deployment of Southwest Microwave's INTREPID™ perimeter security solutions into today's network infrastructure.\*\*

\* Scope of functionality is developer-dependent.

\*\* RPM II SDK offers direct TCP/IP network access. IPP II SDK requires external network device for TCP/IP access.

# FLEXIBLE SDK OPTIONS

Two INTREPID™ SDK toolkits facilitate the development of high-level interface between INTREPID™ Series II perimeter intrusion detection solutions and third-party PSIM, surveillance systems or other custom control applications:



## REMOTE POLLING MODULE II (RPM II) SDK

Part #57A46792-A01

The Remote Polling Module II (RPM II) SDK is an application layer protocol / hardware combination that provides a method for third-party control or monitoring systems to interface with INTREPID™ Series II sensors and auxiliary devices through the INTREPID™ Remote Polling Module II (RPM II) via TCP/IP socket layer. This standard is specific to TCP/IP IPv4 socket communications.

With the RPM II SDK, only the INTREPID™ Remote Polling Module II (RPM II) is queried by the control or monitoring application. By eliminating the need for direct polling of each INTREPID device by the head-end system, the RPM II reduces time, cost and complexity associated with interface development.

Deployment of the RPM II SDK requires the purchase of an INTREPID™ Remote Polling Module II (RPM II) Controller, which handles polling of individual INTREPID™ Series II sensors and auxiliary devices.



## REMOTE POLLING MODULE II (RPM II) SYSTEM CONTROLLER

The Remote Polling Module II (RPM II) is an INTREPID™ System Controller designed to provide network-based large or multi-site facilities with simplified high-level integration (via SDK) between third-party control or monitoring systems and INTREPID™ Series II sensors and auxiliary devices.

The RPM II is a self-contained hardware module with accompanying Software Development Kit (SDK) that eliminates the need for direct polling of each INTREPID™ device by the head-end system, dramatically simplifying interface development. The RPM II serves as Pollmaster - polling all INTREPID™ Series II sensors and auxiliary devices connected to its communications port for status, and communicating this information to the third-party control or monitoring system via TCP/IP network connection. The RPM II also provides secondary relay output interface with 128-zone capability.

### RPM II KEY FEATURES

- PROVIDES INTERFACE VIA SDK TO INTREPID™ SERIES II SYSTEMS
- SECONDARY RELAY OUTPUT INTERFACE (128 ZONES)
- NETWORK-BASED LOCAL OR REMOTE ALARM REPORTING
- LOCAL OR REMOTE RPM II AND SENSOR CONFIGURATION / MAINTENANCE
- SINGLE OR MULTI-SITE MONITORING\*
- CONNECTS UP TO 16 DEVICES
- INTUITIVE SETUP SOFTWARE

### RPM II SPECIFICATIONS

**Operating Temperature:** -40° C to 70° C (-40° F to 158°F)

**Size:** 13.9 H x 33.7 W x 12.7 D cm (5.5 x 13.3 x 5 in)

**Weight:** 1.36 kg (3 lbs)

**Input Power:** 10.5 to 60 VDC

**Current Draw:** 12 VDC: 195 mA, 24 VDC: 100 mA, 48 VDC: 65 mA

**Ports:** RJ45 for network connection (1), USB-B (1), RS422 [2]

**Languages:** English

\* For multi-site applications using the RPM II SDK, each site requires a unique RPM II Network System Controller.



## INTREPID™ POLLING PROTOCOL II (IPP II) SDK

Part #57A46504-A01

The INTREPID™ Polling Protocol II (IPP II) Software Development™ Kit (SDK) is an application layer protocol developed by Southwest Microwave that provides a method for a third-party control or monitoring system to query status and send commands between individual INTREPID™ Series II sensors and auxiliary devices, which include:

MicroPoint™ II - Processor Module II (PM II)  
MicroTrack™ II - MicroTrack™ Processor II (MTP II)  
MicroWave 330  
Alarm Input Module II (AIM II)  
Relay Output Module II (ROM II)

The IPP II protocol uses a packet/frame format to send/receive messages between a master and a slave. This standard is specific to serial line communications.

With the IPP II SDK, each INTREPID™ module is queried individually by the third-party control or monitoring application.

## RPM II EXAMPLE CONFIGURATION DIAGRAM

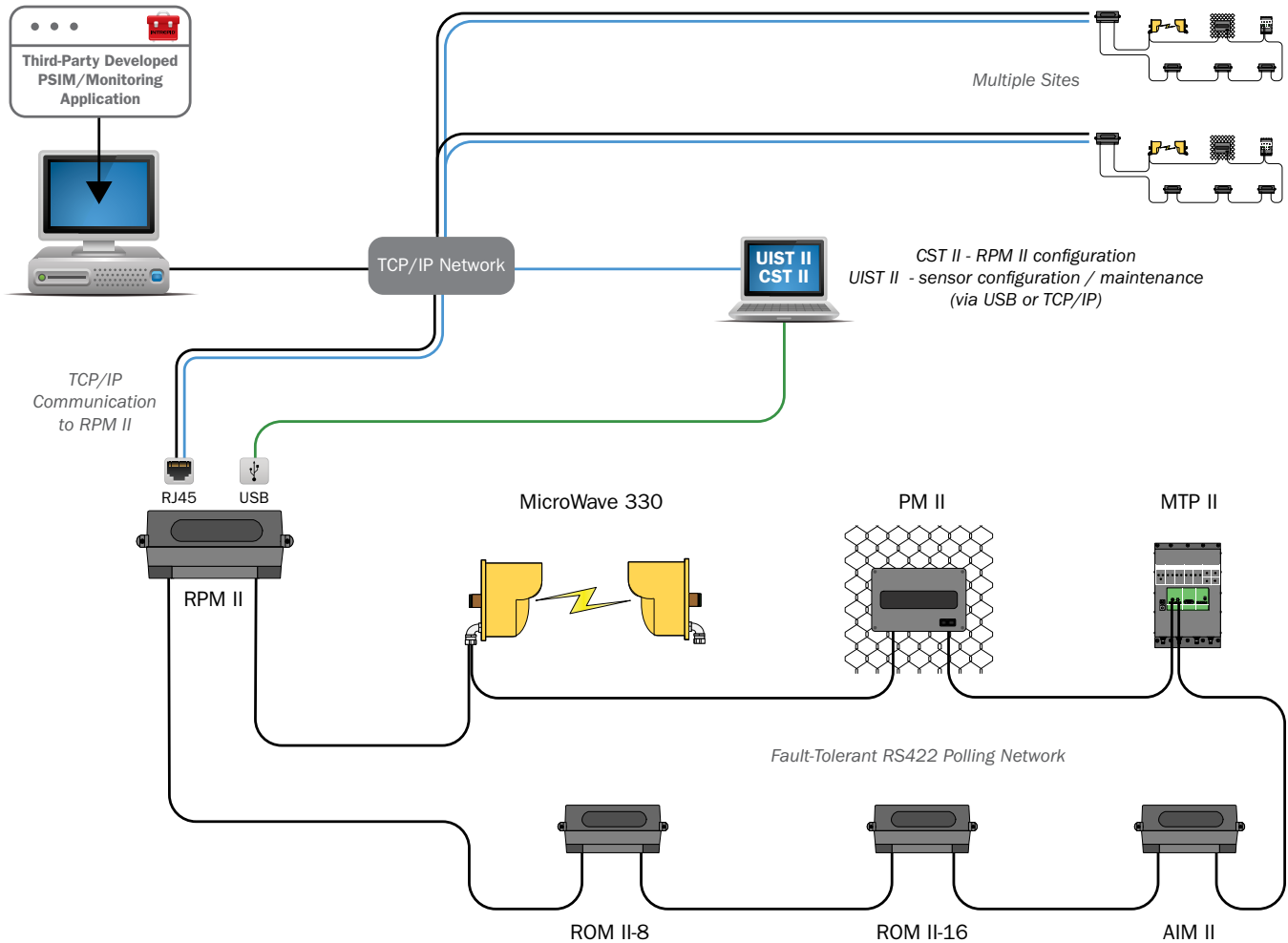

## IPP II EXAMPLE CONFIGURATION DIAGRAM

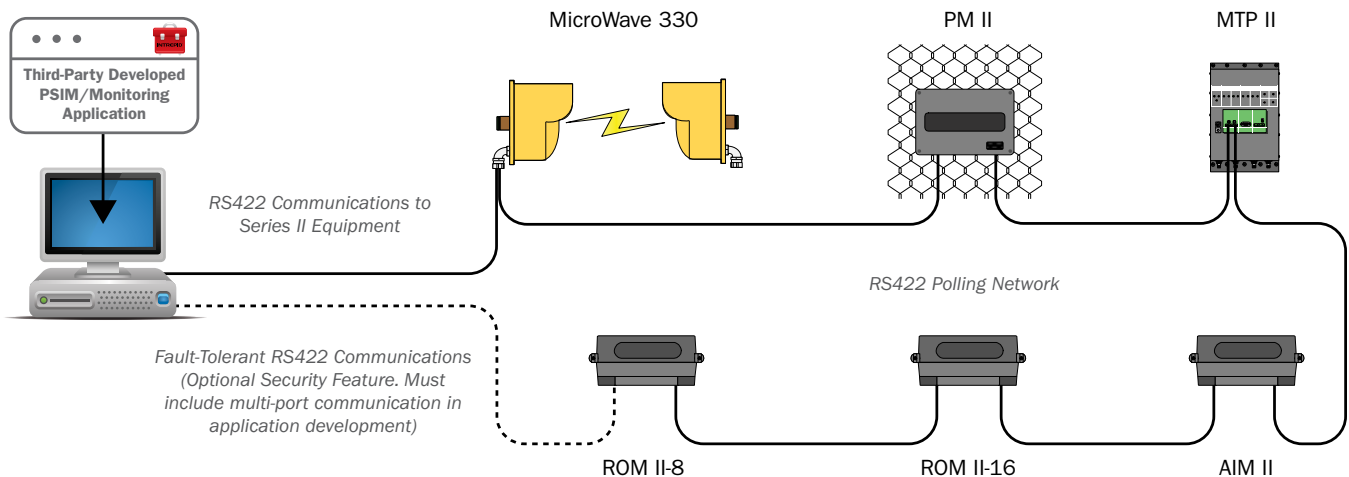

# INTREPID™ SERIES II SDK TECHNICAL QUICK REFERENCE

Southwest Microwave offers two SDK options for integrating INTREPID™ Series II devices with third-party Physical Security Information Management (PSIM) or Video Management System (VMS) platforms. While extensive control and monitoring functionality for our INTREPID™ technologies is achievable via both SDK packages, our new Remote Polling Module II (RPM II) SDK eliminates direct polling of individual INTREPID™ devices, significantly reducing interface programming and test requirements, development cost and time to deployment.

Use the following Technical Quick Reference to learn more about the specifics of each SDK and to determine which protocol best suits your development needs:

INTREPID™ REMOTE POLLING MODULE II (RPM II)	INTREPID™ POLLING PROTOCOL II (IPP II)
<p><b>RPM II SDK Protocol / Hardware Combination</b></p> <ul style="list-style-type: none"> <li>Requires INTREPID™ Remote Polling Module II (RPM II) controller (gateway for communication to INTREPID™ devices).</li> <li>Enables local or remote INTREPID™ device configuration and maintenance via Universal Installation Service Tool II (UIST II).</li> </ul>	<p><b>IPP II SDK Protocol Only</b></p> <ul style="list-style-type: none"> <li>No INTREPID™ polling hardware required.</li> </ul>
<p><b>Single Point Polling Structure</b></p> <ul style="list-style-type: none"> <li>Requires development of one (1) alarm polling routine between PSIM/VMS and RPM II controller.</li> <li>PSIM/VMS polls RPM II at set interval. Polling may be synchronous or asynchronous.</li> <li>RPM II polls and receives alarm information for connected INTREPID™ devices at fixed intervals of 125 ms.</li> <li>Polling routine is identical regardless of number/type of INTREPID™ devices connected to RPM II or number of RPM II controllers being polled.</li> </ul>	<p><b>Device Level Polling Structure</b></p> <ul style="list-style-type: none"> <li>Requires development of a unique alarm polling routine for each INTREPID™ device type*.</li> <li>A separate polling message is sent by PSIM/VMS to each INTREPID™ device.</li> <li>PSIM/VMS receives alarm information directly from each INTREPID™ device.</li> <li>Polling interval is variable based on number of devices on RS422 line.</li> </ul>
<p><b>Site Size Limitations</b></p> <ul style="list-style-type: none"> <li>Maximum of 16 devices per RPM II.</li> <li>Unlimited RPM IIs may be incorporated per site.</li> <li>Multiple sites may reside on common IP Network.</li> <li>Alarm delivery time is unaffected by adding additional RPM II controllers.</li> </ul>	<p><b>Site Size Limitations</b></p> <ul style="list-style-type: none"> <li>240 devices per RS422 connection.</li> <li>To maintain a 1 second alarm delivery time, up to 8 INTREPID™ devices may be polled via a single RS422 port. Each additional device increases alarm delivery time by 150 ms per device.</li> </ul>
<p><b>Programming Structure</b></p> <ul style="list-style-type: none"> <li>Basic socket programming.</li> <li>Standard is specific to TCP/IP IPv4 socket communications.</li> </ul>	<p><b>Programming Structure</b></p> <ul style="list-style-type: none"> <li>Packet/frame format.</li> <li>Standard is specific to serial line communications.</li> </ul>
<p><b>System Management Capabilities</b></p> <ul style="list-style-type: none"> <li><i>Supports Basic Authentication:</i> Password required on connection to RPM II.</li> <li><i>Redundant System Communications:</i> Two independent PSIM/VMS stations can poll RPM II simultaneously.</li> <li><i>Fault Tolerance:</i> Two communications ports on RPM II enable bi-directional polling of INTREPID™ devices by RPM II.</li> <li><i>Secondary Relay Output Interface (128 Zones)</i></li> </ul>	<p><b>System Management Capabilities</b></p> <ul style="list-style-type: none"> <li><i>No Authentication Support:</i> Password not required when connecting to INTREPID™ devices.</li> <li><i>No System Communications Redundancy:</i> Only one PSIM/VMS station can directly poll the INTREPID™ system.</li> <li><i>Fault Tolerance:</i> Requires development of a fault tolerant polling program by developer.</li> </ul>

Contact us at [infosd@southwestmicrowave.com](mailto:infosd@southwestmicrowave.com) for further information or to request INTREPID™ SDK documentation.

\* INTREPID™ device types include: MicroPoint™ Processor Module II (PM II), MicroNet™ Processor Module II (MPM II), MicroTrack™ Processor II (MTP II), MicroWave 330 Rx, Alarm Input Module II (AIM II), Relay Output Module II 8 (ROM II-8), Relay Output Module 16 (ROM II-16). When selecting the IPP II protocol, the Developer is encouraged to include all INTREPID™ Series II device types in the scope of interface development, since projects often contain multiple INTREPID™ device types, either from inception or during future expansion.

INTREPID™, MicroTrack™, MicroPoint™ and MicroNet™ are trademarks of Southwest Microwave, Inc.

**USA (CORPORATE HEADQUARTERS):**  
Southwest Microwave, Inc., Arizona, USA  
Telephone +1 (480) 783-0201

**EUROPEAN OFFICES:**  
Southwest Microwave Ltd., Worcestershire, UK  
Telephone +44 1386 75 15 11

**MIDDLE EAST OFFICES:**  
Southwest Microwave, Inc., Dubai, UAE  
Telephone: +971 4 371 2624