

# INTREPID™ MicroNet™ II

FENCE DETECTION SYSTEM - U.S. CORRECTIONS

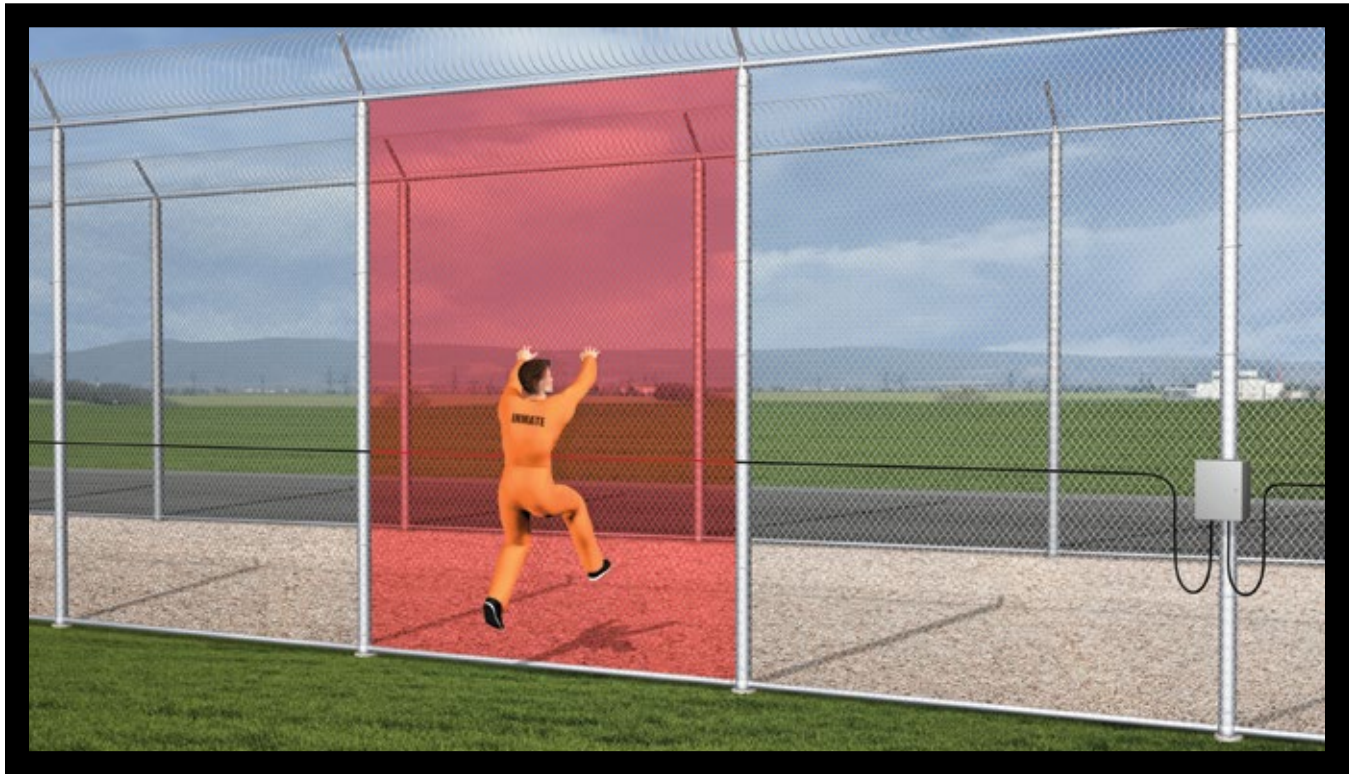

INTREPID™ MicroNet™ II is the new-generation version of Southwest Microwave's field-proven MicroNet™ perimeter fence detection system, designed for applications where the detection of cut or climb attempts is required. A newly enhanced FSK communications system increases the range for system communication across the sensor cables.

MicroNet™ II is the industry's highest performing fence sensor, using proprietary Digital Signal Processing (DSP) algorithms to precisely locate escape attempts to within 3 meters (10 ft) while ignoring harmless disturbances caused by wind, rain or vehicle traffic. The system's superior signal-to-noise ratio, bandwidth and dynamic range produce superior probability of detection and a very low false / nuisance alarm rate (FAR/NAR).

With a coverage area of 400 meters (1312 ft) per processor, the MicroNet™ II system consists of a MicroNet™ Processor Module and two MicroPoint™ sensor cables that are tie-wrapped to a perimeter fence or topper wire. The MicroNet™ Processor Module provides the system intelligence to perform powerful alarm signal processing, DC power distribution and data communications networking (via FSK), eliminating the need for extra wiring. The MicroPoint™ cable detects fence vibrations, permits easy connection of the perimeter system and supports DC power, data communications and escape detection capabilities.

Detection zones are set in software to cost-effectively tailor zoning to suit a correctional facility's unique requirements.

As part of the new-generation INTREPID™ family, MicroNet™ II may also be networked with the MicroTrack™ II Buried Cable Sensor and MicroWave 330 Digital MicroWave Link using a common, open architecture communications protocol.

## KEY FEATURES

- SINGLE PLATFORM NETWORKING CAPABILITIES
- ESCAPE LOCATION TO 3 M (10 FT)
- ADVANCED DIGITAL SIGNAL PROCESSING
- SOLVES ENVIRONMENTAL NUISANCE ALARM PROBLEMS
- SITE-ADAPTIVE SENSITIVITY LEVELING™
- SOFTWARE CONTROLLED ZONING
- UNIFORM DETECTION ALONG FENCELINE
- FOUR SYSTEM CONTROLLER OPTIONS PLUS AVAILABLE SDK



# INTREPID™ MicroNet™ II

## FENCE DETECTION SYSTEM - U.S. CORRECTIONS

### PRINCIPLES OF DETECTION AND LOCATION

MicroNet™ II sensor cables are divided into cells via system software. There are typically 200 cells per 200 m (656 ft) cable.

To initiate detection, the MicroNet™ II processor sends a pulse down the cable using the principles of Time Domain Reflectometry (TDR). The pulse is reflected back by a disturbance to the fence, providing location of the event along the length of cable.

#### SENSITIVITY LEVELING™

A calibration walk is performed to optimize detection sensitivity within each 1.1 meter (3.6 ft) cell by accounting for variations in fence fabric or tension. A sensitivity profile is then generated across all cells and the alarm threshold is set.

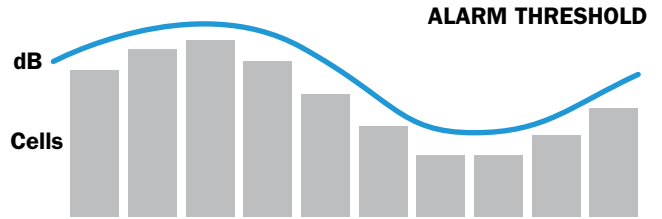

#### PERIMETER FENCE

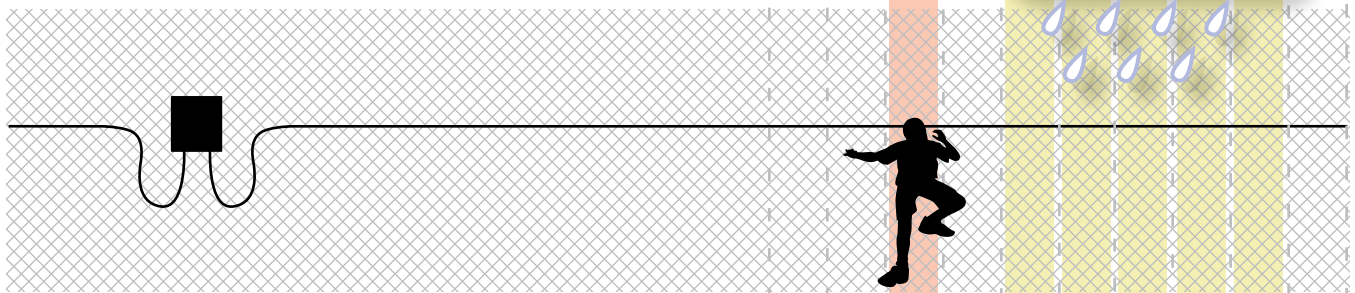

When a target makes contact with the fence, the received signal is sampled to create a signature which describes the reflected pulse. Digital Signal Processing (DSP) measures the location and shape of this pulse. The microprocessor can differentiate the shape of a response from a Point Impact (cut or climb attempt) vs. a response caused by a Distributed Disturbance (rain, wind, vehicle traffic).

If the target is recognized as a Point Impact and exceeds the threshold, an alarm is declared and its precise location identified.

#### PRECISE LOCATION OF ALARMS

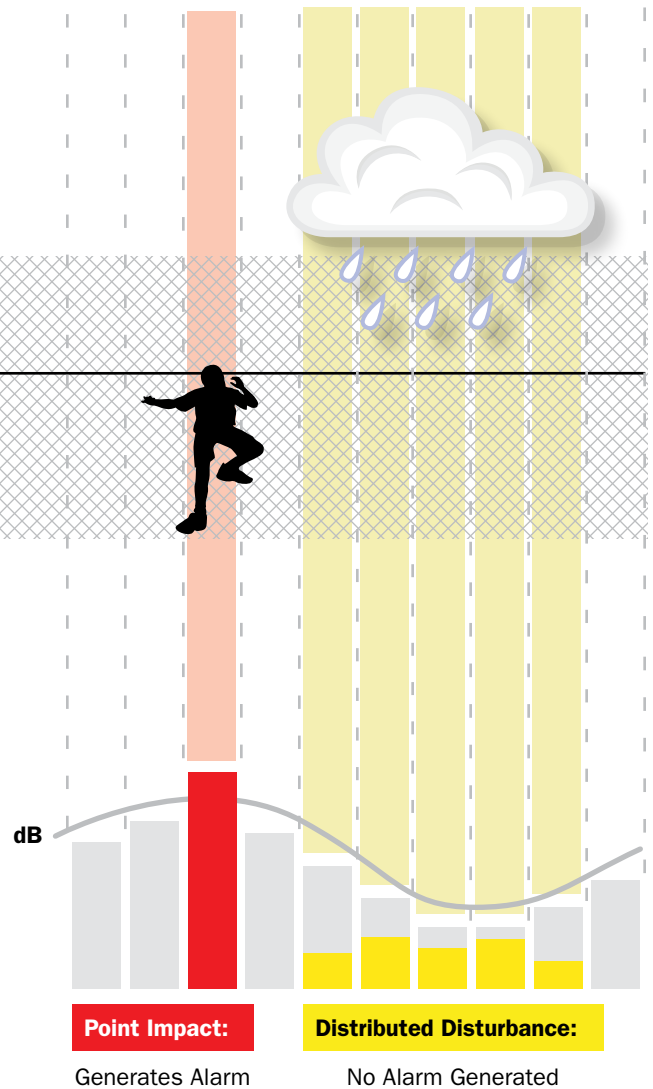

# FEATURES AND BENEFITS

## PRECISE TARGET LOCATION

The ability to locate escape attempts to within 3 m (10 ft) anywhere along the cable.

## FREE FORMAT ZONING

Zones are controlled via system software - independent of processor location - keeping hardware costs low and offering maximum flexibility. The number and location of zones can be easily altered to meet changing site conditions.

## SENSITIVITY LEVELING™

A proprietary calibration process accounts for variations in fence fabric or tension to provide uniform detection sensitivity along the fenceline.

## REMOTE DIAGNOSTICS

Monitor and control system status, detection parameters and alarm information for easy troubleshooting or adjustment.\*\*

## INTEGRATED I/O MODULES

Auxiliary input modules\* can be used to incorporate auxiliary devices, such as Southwest Microwave's conventional sensors, gate and door contacts or other alarm contacts. 8 or 16-port relay output modules\* provide simple interface to CCTV, legacy alarm panels, perimeter lighting or other relays if high-level interface is not available.

## POINT IMPACT DISCRIMINATION™

Identifies localized attempts to cut or climb the fence, but ignores distributed fence noise generated by wind, rain or vehicle traffic - solving the nuisance alarm problems that plague conventional fence sensors.

## SEAMLESS NETWORKING CAPABILITIES

MicroNet™ II sensors are networked via standard RS422 serial data interface using a common open-architecture communications protocol - the INTREPID™ Polling Protocol II. INTREPID™ MicroTrack™ II, MicroWave 330 and I/O modules may also be networked within the system.\*

## FSK COMMUNICATIONS

MicroNet™ II is equipped with an advanced internal FSK communications system that supports DC power, alarm processing and data communications across the sensor cables, using the INTREPID™ Polling Protocol II.

## SCALABLE SYSTEM CONTROLLERS

A universal INTREPID™ system controller conveniently manages all new-generation INTREPID™ sensors and I/O modules. Four available controller options offer scalable security management solutions to suit any site parameters. An SDK is available for high level integration of new generation INTREPID™ sensors into custom control applications.\*

\* See INTREPID™ System Controllers data sheet and Configuration Diagrams for complete specifications.

\*\* Requires CM II or GCM II System Controller

## TYPICAL MICRONET™ II SYSTEM CONFIGURATION DIAGRAM

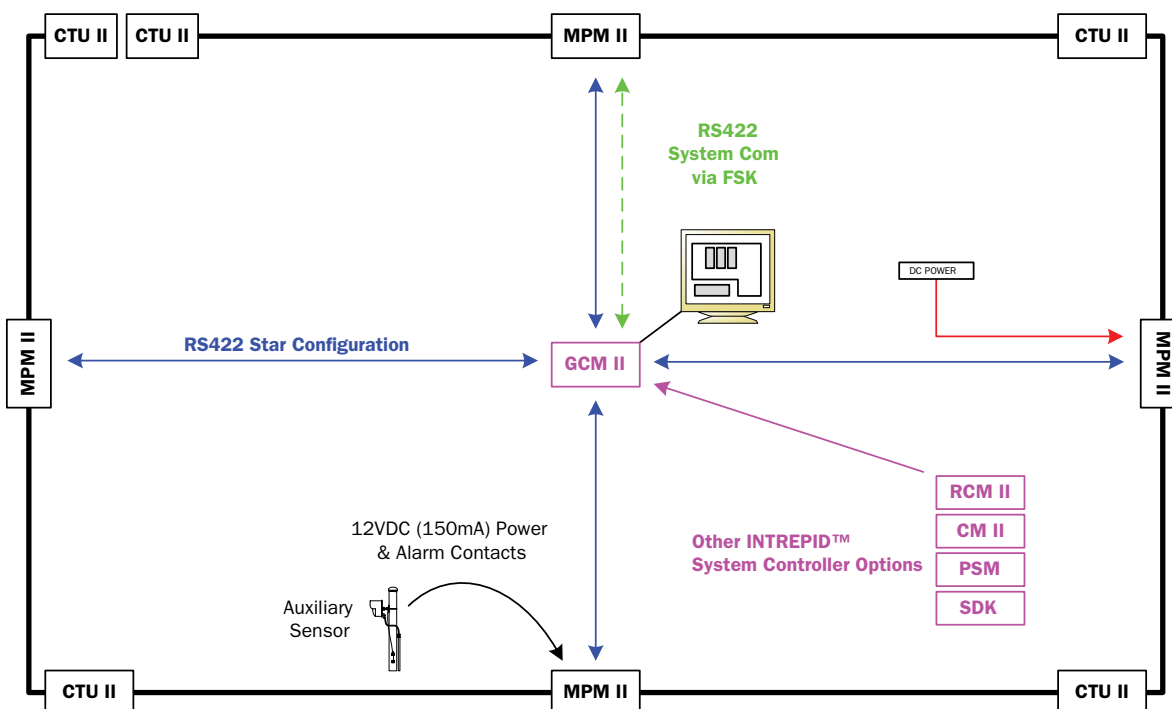

# INTREPID™ MicroNet™ II

## SYSTEM COMPONENTS & SPECIFICATIONS



### MICRONET™ PROCESSOR MODULE II (MPM II)

Housed in a rugged NEMA 4 steel enclosure, each MicroNet™ Processor Module II processes data from two lengths of MicroPoint™ cable (A and B). Each length of transducer cable can be up to 200 m (656 feet) long. Both A and B lengths of transducer cable are terminated in either Coupler / Termination Units or Termination Units.

**Size:** 305 H x 356 W x 152 D mm (12 x 14 x 6 in)  
**Weight:** 11.34 kg (25 lbs)  
**Operating Temperature:** -40° C to 70° C (-40° F to 159° F)  
**Power:** 10.5 to 60 VDC at 13 watts (without aux. sensors)  
**Current Draw:** 12 VDC at 650 mA, 24 VDC at 335 mA and 48 VDC at 185 mA  
**Inputs:** 2 MicroPoint™ cables (A and B), 4 Dry Contact Inputs  
**Ports:** RS232 [1], RS422 [2]

### MICROPOINT™ CABLE (MC-115)

The MicroPoint™ cable is used for detection, power distribution and data communications.

#### MC-115 Type (Standard)

**Size:** 4.902 mm (0.193 in) diameter  
**Jacket:** High density polyethylene, UV resistant, black.  
**Operating Temperature:** -40° C to 70° C (-40° F to 159° F)  
**Minimum Bend Radius:** 63.5 mm (2.5 in)  
**Packaged Size: Packaged Weight:**  
100 m (328 ft) 4 kg (9 lbs)  
220 m (722 ft) 9.1 kg (20 lbs)

#### MC-315-Type (Armored)

**Size:** 6.45 mm (0.254 in) diameter  
**Jacket:** High density polyethylene, UV resistant, black.  
**Operating Temperature:** -40° C to 70° C (-40° F to 159° F)  
**Minimum Bend Radius:** 63.5 mm (2.5 in)  
**Packaged Size: Packaged Weight:**  
100 m (328 ft) 15 kg (33 lbs)  
220 m (722 ft) 26 kg (37 lbs)

### INTREPID™ SYSTEM CONTROLLERS

Four system control options, optional I/O modules and available SDK offer scalable security management solutions for virtually any site parameters\*.

### UNIVERSAL INSTALLATION SERVICE TOOL II (UIST II)

Universal installation service software configures INTREPID™ MicroNet™ II with laptop convenience at each module via RS232 connection. Sensor autodiscovery, guided navigation and forward propagation simplify set-up and calibration. Configuration security allows lockdown of device settings, ensuring implementation of approved changes only. Remotely adjust via TCP/IP\*\* connection, even when the system is operational.

### COUPLER / TERMINATION UNIT II (CTU II)

Coupler / Termination Unit II's are used at the ends of the A and B MicroPoint™ cables. They terminate the detection process and provide a means of interconnecting multiple MicroNet™ II processor modules with FSK and power.

**Size:** 368 mm L x 50.8 mm Dia. (14.5 in L x 2 in Dia.)  
**Weight:** 1.08 kg (2.4 lbs)  
**Operating Temperature:** -40° C to 70° C (-40° F to 159° F)  
**Inputs:** 2 MicroPoint™ cables

### TERMINATION UNIT II (TU II)

The Termination Unit II is used at the end-of-line in an open loop configuration to terminate detection process.

**Size:** 133 H x 64 W x 76 D mm (5.25 x 2.5 x 3.0 in)  
**Weight:** 0.45 kg (1 lb)  
**Operating Temperature:** -40° C to 70° C (-40° F to 159° F)  
**Inputs:** 1 MicroPoint™ cable

### ACCESSORIES:

**Optional Stainless Steel Enclosure**  
**Heavy Duty DC Power Supplies**  
**MicroPoint Cable Splice Kit (SU)**



\*See INTREPID™ System Controllers data sheet and Configuration Diagrams for complete specifications.

\*\*Requires CM II, GCM II

INTREPID™, MicroNet™, MicroPoint™, MicroTrack™ and Sensitivity Leveling™ are trademarks of Southwest Microwave, Inc. Specifications subject to change without notice.



**USA (CORPORATE HEADQUARTERS):** Southwest Microwave, Inc., Arizona, USA | Telephone +1 (480) 783-0201

**EUROPEAN OFFICES:** Southwest Microwave Ltd., Worcestershire, UK | Telephone +44 1386 75 15 11