

# INTREPID™ MicroPoint™ II

FENCE DETECTION SYSTEM

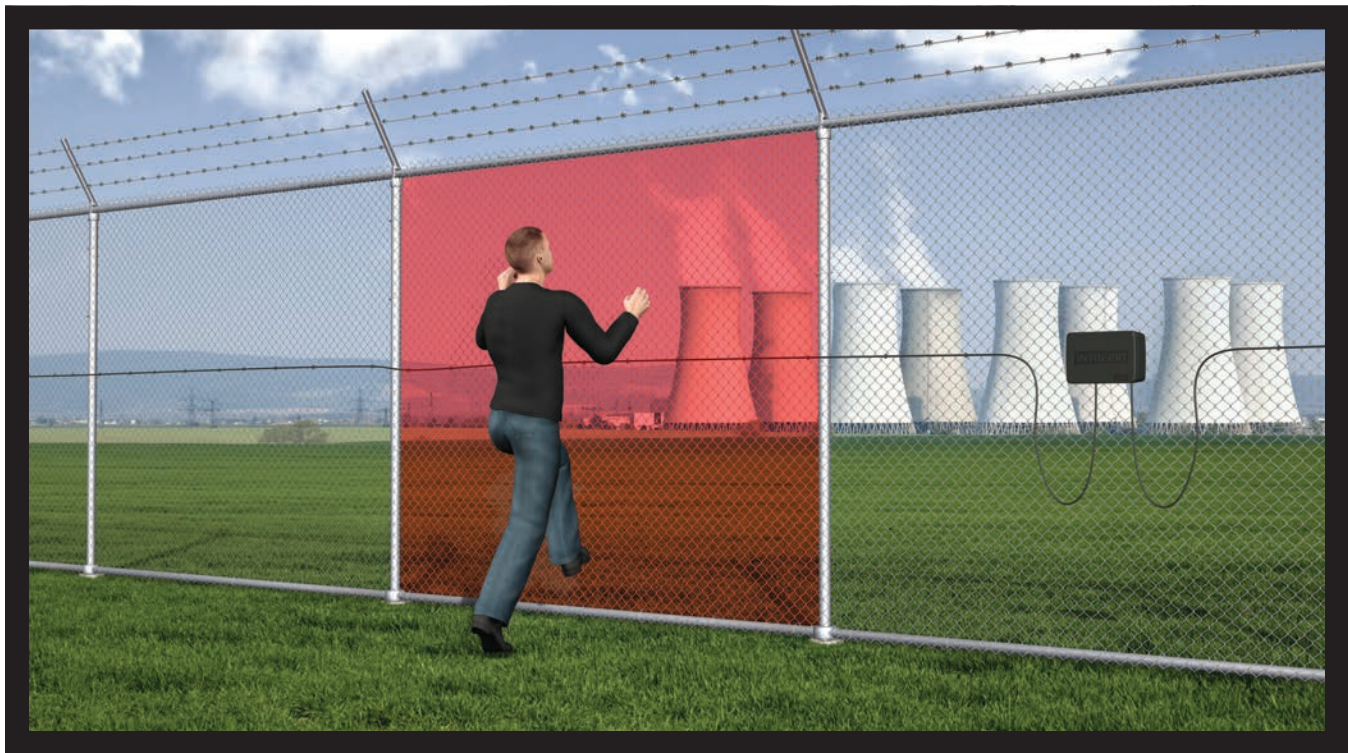

INTREPID™ MicroPoint™ II is the new-generation version of Southwest Microwave's field-proven perimeter fence detection system for applications where the detection of cut or climb attempts is required. A newly enhanced FSK communications system increases the range for system communication across the sensor cables.

MicroPoint™ II is the industry's highest performing fence sensor, using proprietary Digital Signal Processing (DSP) algorithms to precisely locate intrusion attempts to within 3 meters (10 ft) while ignoring harmless disturbances caused by wind, rain or vehicle traffic. The system's superior signal-to-noise ratio, bandwidth and dynamic range produce superior probability of detection and a very low false / nuisance alarm rate (FAR/NAR).

With a coverage area of 400 meters (1312 ft) per processor, the MicroPoint™ II system consists of a Processor Module and two sensor cables that are tie-wrapped to a perimeter fence or topper wire. The Processor Module provides the system intelligence to perform powerful alarm signal processing, DC power distribution and data communications networking (via FSK), eliminating the need for extra wiring. The MicroPoint™ cable detects fence vibrations, permits easy connection of the perimeter system and supports DC power, data communications and intrusion detection capabilities.

Detection zones are set in software to cost-effectively tailor zoning to suit a site's unique requirements.

As part of the new-generation INTREPID™ family, MicroPoint™ II may also be networked with the MicroTrack™ II Buried Cable Sensor and MicroWave 330 Digital MicroWave Link using a common, open architecture communications protocol.

## KEY FEATURES

- SINGLE PLATFORM NETWORKING CAPABILITIES
- INTRUSION LOCATION TO 3 M (10 FT)
- ADVANCED DIGITAL SIGNAL PROCESSING
- SOLVES ENVIRONMENTAL NUISANCE ALARM PROBLEMS
- SITE-ADAPTIVE SENSITIVITY LEVELING™
- SOFTWARE CONTROLLED ZONING
- UNIFORM DETECTION ALONG FENCELINE
- FOUR SYSTEM CONTROLLER OPTIONS PLUS AVAILABLE SDK



# INTREPID™ MicroPoint™ II

FENCE DETECTION SYSTEM

## PRINCIPLES OF DETECTION AND LOCATION

MicroPoint™ sensor cables are divided into cells via system software. There are typically 200 cells per 200 m (656 ft) cable.

To initiate detection, the MicroPoint™ II processor sends a pulse down the cable using the principles of Time Domain Reflectometry (TDR). The pulse is reflected back by a disturbance to the fence, providing location of the event along the length of cable.

### SENSITIVITY LEVELING™

A calibration walk is performed to optimize detection sensitivity within each 1.1 meter (3.6 ft) cell by accounting for variations in fence fabric or tension. A sensitivity profile is then generated across all cells and the alarm threshold is set.

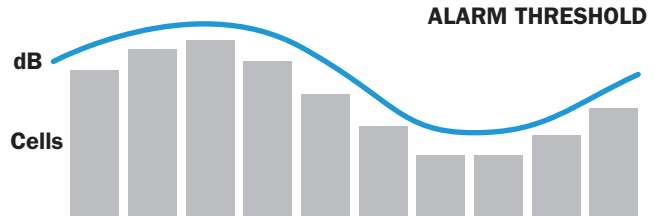

### PERIMETER FENCE

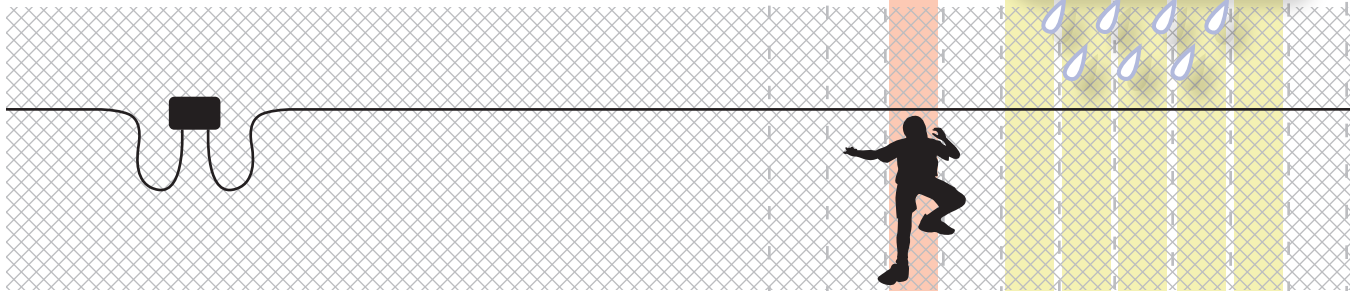

When a target makes contact with the fence, the received signal is sampled to create a signature which describes the reflected pulse. Digital Signal Processing (DSP) measures the location and shape of this pulse. The microprocessor can differentiate the shape of a response from a Point Impact (cut or climb attempt) vs. a response caused by a Distributed Disturbance (rain, wind, vehicle traffic).

If the target is recognized as a Point Impact and exceeds the threshold, an alarm is declared and its precise location identified.

### PRECISE LOCATION OF ALARMS

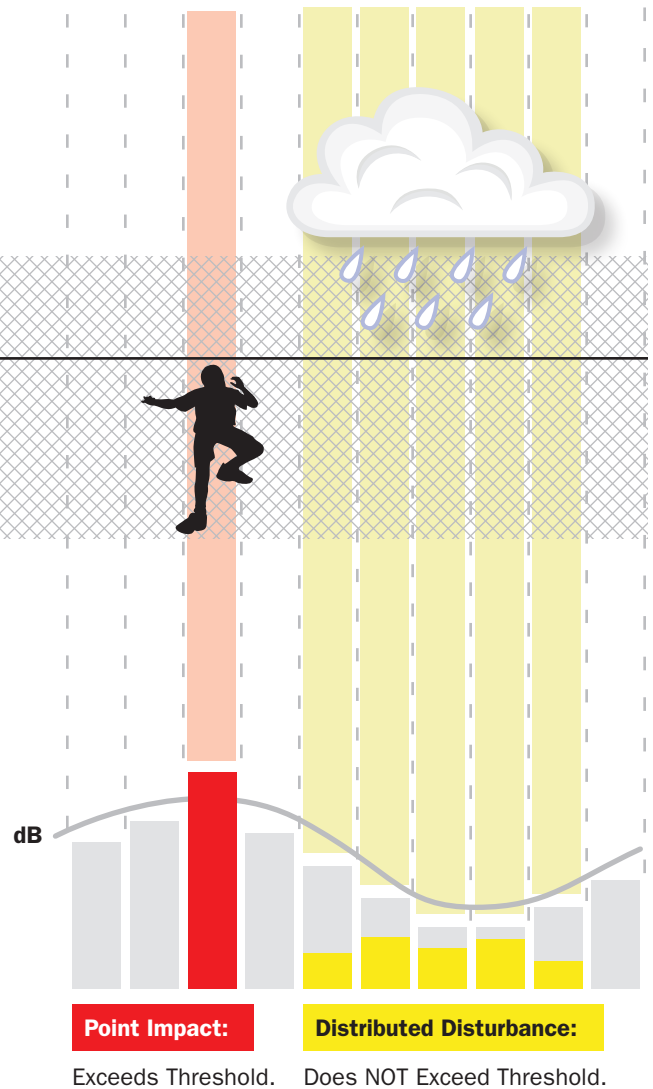

# FEATURES AND BENEFITS

## PRECISE TARGET LOCATION

The ability to locate intruders to within 3 m (10 ft) anywhere along the cable.

## FREE FORMAT ZONING

Zones are controlled via system software - independent of processor location - keeping hardware costs low and offering maximum flexibility. The number and location of zones can be easily altered to meet changing site conditions.

## SENSITIVITY LEVELING™

A proprietary calibration process accounts for variations in fence fabric or tension to provide uniform detection sensitivity along the fenceline.

## REMOTE DIAGNOSTICS

Monitor and control system status, detection parameters and alarm information for easy troubleshooting or adjustment.\*\*

## INTEGRATED I/O MODULES

Auxiliary input modules\* can be used to incorporate auxiliary devices, such as Southwest Microwave's conventional sensors, gate and door contacts or other alarm contacts. 8 or 16-port relay output modules\* provide simple interface to CCTV, legacy alarm panels, perimeter lighting or other relays if high-level interface is not available.

## POINT IMPACT DISCRIMINATION™

Identifies localized attempts to cut or climb the fence, but ignores distributed fence noise generated by wind, rain or vehicle traffic - solving the nuisance alarm problems that plague conventional fence sensors.

## SEAMLESS NETWORKING CAPABILITIES

MicroPoint™ II sensors are networked via standard RS422 serial data interface using a common open-architecture communications protocol - the INTREPID™ Polling Protocol II. INTREPID™ MicroTrack™ II, MicroWave 330 and I/O modules may also be networked within the system.\*

## FSK COMMUNICATIONS

MicroPoint™ II is equipped with an advanced internal FSK communications system that supports DC power, alarm processing and data communications across the sensor cables, using the INTREPID™ Polling Protocol II.

## SCALABLE SYSTEM CONTROLLERS

A universal INTREPID™ system controller conveniently manages all new-generation INTREPID™ sensors and I/O modules. Four available controller options offer scalable security management solutions to suit any site parameters. An SDK is available for high level integration of new generation INTREPID™ sensors into custom control applications.\*

\* See INTREPID™ System Controllers data sheet and Configuration Diagrams for complete specifications.

\*\* Requires CM II or GCM II System Controller

## TYPICAL MICROPOINT™ SYSTEM CONFIGURATION DIAGRAM

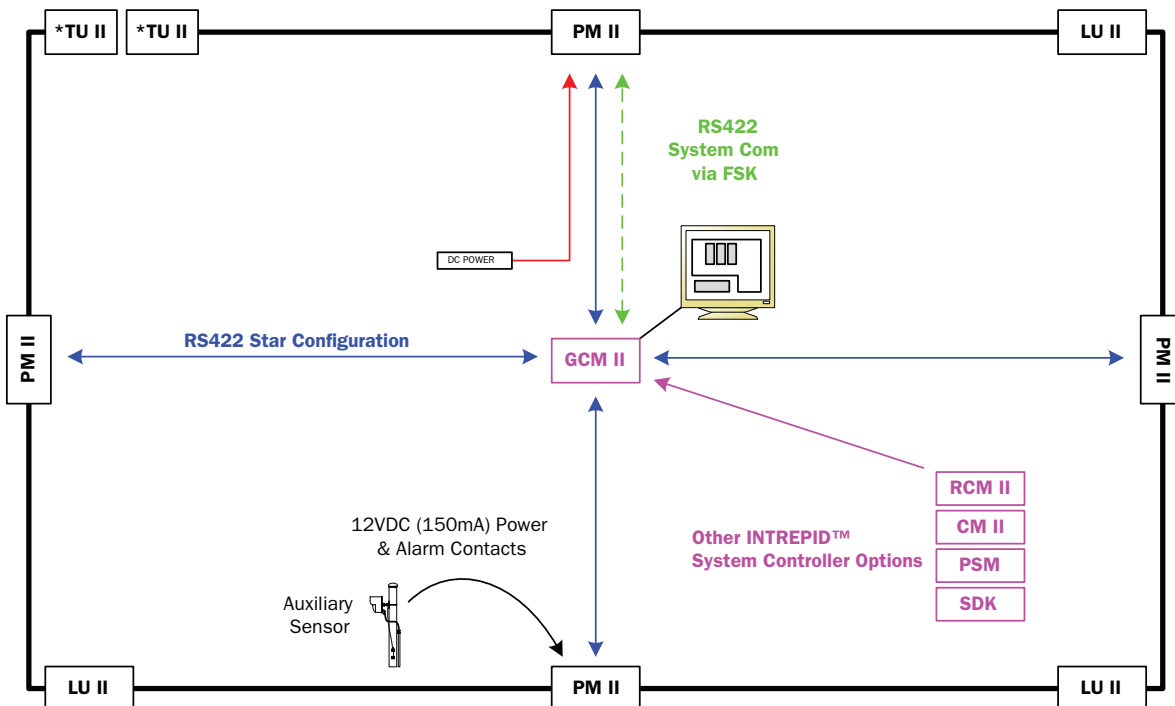

\*TU's Required for Star & FSK Communication Configurations

# INTREPID™ MicroPoint™ II

## SYSTEM COMPONENTS & SPECIFICATIONS



### PROCESSOR MODULE II (PM II)

Each module processes data from two lengths of MicroPoint™ cable (A and B). Each length of transducer cable can be up to 200 m (656 feet) long. Both A and B lengths of transducer cable are terminated in either Link Units or Termination Units.

**Size:** 268 H x 333 W x 108 D mm (8.59 x 13.11 x 4.26 in)  
**Weight:** 1.81 kg (4 lbs)  
**Operating Temperature:** -40° C to 70° C (-40° F to 159° F)  
**Power:** 10.5 to 60 VDC at 13 watts (without aux. sensors)  
**Current Draw:** 12 VDC at 650 mA, 24 VDC at 335 mA and 48 VDC at 185 mA  
**Inputs:** 2 MicroPoint™ cables (A and B), 4 Dry Contact Inputs  
**Ports:** RS232 [1], RS422 [2]

### MICROPOINT™ CABLE (MC-115)

The MicroPoint™ cable is used for detection, power distribution and data communications.

#### MC-115 Type (Standard)

**Size:** 4.902 mm (0.193 in) diameter  
**Jacket:** High density polyethylene, UV resistant, black.  
**Operating Temperature:** -40° C to 70° C (-40° F to 159° F)  
**Minimum Bend Radius:** 63.5 mm (2.5 in)  
**Packaged Size:**   **Packaged Weight:**  
100 m (328 ft)    4 kg (9 lbs)  
220 m (722 ft)    9.1 kg (20 lbs)

#### MC-315-Type (Armored)

**Size:** 6.45 mm (0.254 in) diameter  
**Jacket:** High density polyethylene, UV resistant, black.  
**Operating Temperature:** -40° C to 70° C (-40° F to 159° F)  
**Minimum Bend Radius:** 63.5 mm (2.5 in)  
**Packaged Size:**   **Packaged Weight:**  
100 m (328 ft)    15 kg (33 lbs)  
220 m (722 ft)    26 kg (37 lbs)

### INTREPID™ SYSTEM CONTROLLERS

Four system control options, optional I/O modules and available SDK offer scalable security management solutions for virtually any site parameters\*.

### UNIVERSAL INSTALLATION SERVICE TOOL II (UIST II)

Universal installation service software configures INTREPID™ MicroPoint™ with laptop convenience at each module via RS232 connection. Sensor autodiscovery, guided navigation and forward propagation simplify set-up and calibration. Configuration security allows lockdown of device settings, ensuring implementation of approved changes only. Remotely adjust via TCP/IP\*\* connection, even when the system is operational.

### LINK UNIT II (LU II)

Link Units are used at the ends of the A and B MicroPoint™ cables. They terminate the detection process and provide a means of interconnecting multiple Processor Modules with FSK and power.

**Size:** 268 H x 333 W x 108 D mm (8.59 x 13.11 x 4.26 in)  
**Weight:** 1.59 kg (3.5 lbs)  
**Operating Temperature:** -40° C to 70° C (-40° F to 159° F)  
**Inputs:** 2 MicroPoint™ cables

### TERMINATION UNIT II (TU II)

The Termination Unit II is used at the end-of-line in an open loop configuration to terminate detection process.

**Size:** 133 H x 64 W x 76 D mm (5.25 x 2.5 x 3.0 in)  
**Weight:** 0.45 kg (1 lb)  
**Operating Temperature:** -40° C to 70° C (-40° F to 159° F)  
**Inputs:** 1 MicroPoint™ cable

### ACCESSORIES:

**Heavy Duty DC Power Supplies**  
**MicroPoint Cable Splice Kit (SU)**

\* See INTREPID™ System Controllers data sheet and Configuration Diagrams for complete specifications.

\*\* Requires CM II, GCM II



Intrepid™ MicroPoint™ is approved for UK Government use. For details contact CPNI.

INTREPID™, MicroPoint™, MicroTrack™ and Sensitivity Leveling™ are trademarks of Southwest Microwave, Inc. Specifications subject to change without notice.



**USA (CORPORATE HEADQUARTERS):** Southwest Microwave, Inc., Arizona, USA | Telephone +1 (480) 783-0201

**EUROPEAN OFFICES:** Southwest Microwave Ltd., Worcestershire, UK | Telephone +44 1386 75 15 11