

TECHNICAL NOTE # 905

Re: Identifying Unmarked MicroTrack Sensor Cables
Date: January 3, 2013

INTRODUCTION

This procedure describes a method to identify unmarked MicroTrack Sensor Cables using the MicroTrack Processor II (MTP II), Universal Installation Service Tool II (UIST II) and a Test Cable. This may be required if the cables were not properly installed and labeled per the manual. This procedure applies to both the MicroTrack and MicroTrack II sensors.

The Test Cable is made by taking a MicroTrack Lead-In Cable and attaching about 3 ft (.91m) of insulated wire (10 to 24 AWG) to the center conductor as is shown in Figure 1. The MicroTrack Lead-In Cable can be purchased as part of the Lead-In Cable Assembly Repair Kit (02A45909-A01). The Lead-In Cable is not damaged and can be used as a replacement cable later, if needed.

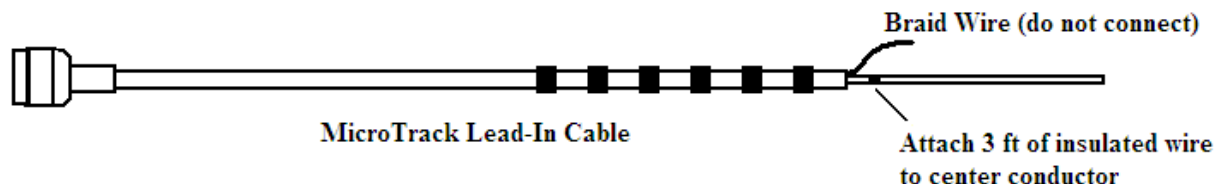

Figure 1

As an example, there is a configuration using three (3) MTP II processors and the lead-in cables are not marked as shown in Figure 2. In order to determine cable A, B, TX and RX, perform the following steps. *Note: the numbers above the cables refer to the trench locations.*

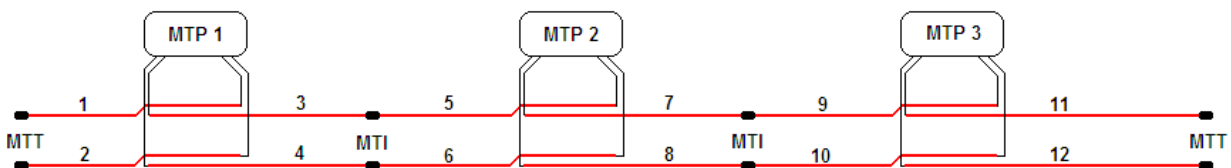

Figure 2

- The first step is to determine how the system is to be configured. There are two (2) steps: 1 - identifying the A and B sides for each MTP II and 2 - selecting one trench for the TX cables and the other trench for the RX cables. There are two basic rules: 1 - Never connect A to A, or B to B. The configuration must always have A to B at every junction. 2 - All of the TX cables must be in one trench, and all of the RX cables must be in the other trench. A TX cable can never be against or connected to a RX cable. It does not matter which trench is TX or RX. An example of this assignment is shown in Figure 3.

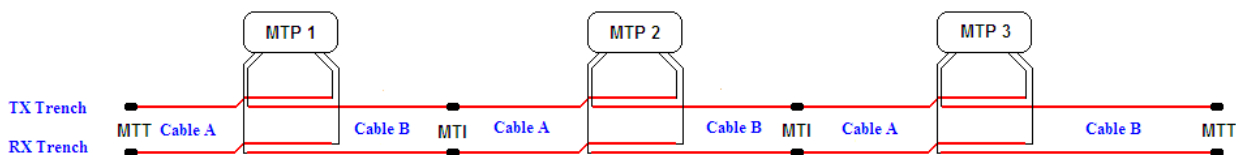

Figure 3

- Using Figure 3 as a reference, each of the MTP II's can now be identified as shown in Figure 4. This process is the same for each of the MTP II's. This example will start with MTP 1.

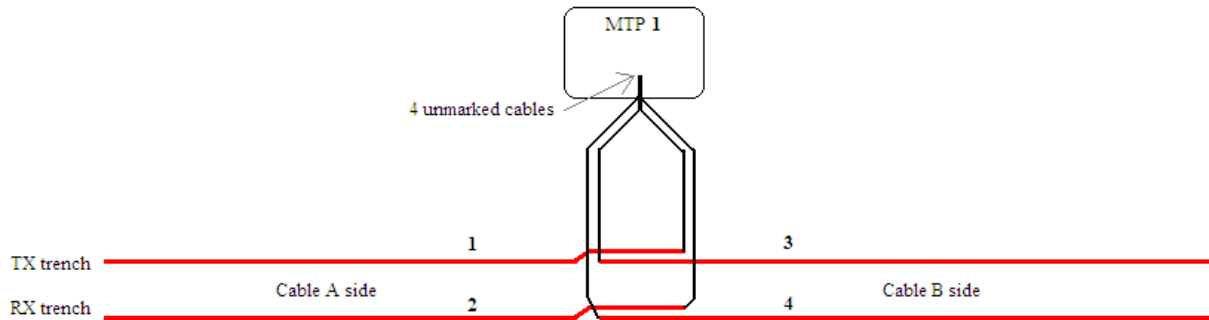

Figure 4

- Disconnect the power on all other MTP II's except for the one being worked on. Randomly select one of the four unmarked lead-in cables and connect it to the TX A port on the MTP II. All of the other three cables must be disconnected.
- Connect the Test Cable to the RX A port of the MTP II. This Test Cable will act as the receive antenna for the MTP II. Take the free end of the Test Cable and lay it over the top of one of the four MicroTrack cable trenches. Stretch the Test Cable out to its maximum length to be sure that it is **outside** of the startup overlap area by at least 6 ft (1.8 m) as shown in Figure 5.

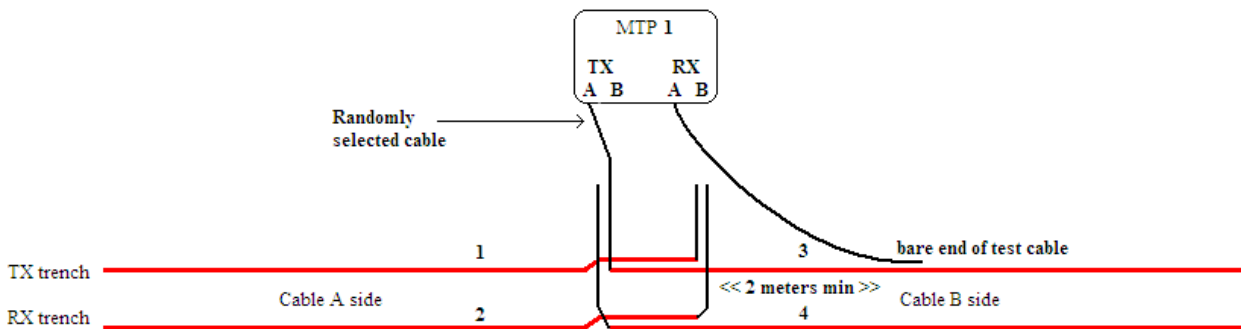

Figure 5

- On the UIST II, select the Clutter Input Screen for Cable A. Restore the defaults on the MTP II and allow it to set the Channel Gain value (also known as the AGC value) as shown in Figure 6.

Move the Test Cable to each of the four buried cables and repeat step (5) for each one. The trench with the LOWEST Channel Gain value is the cable that is currently connected to the TX A port. In this example, the cable in trench 3 has the lowest Channel Gain (34), so this cable is the one that is currently connected to the TX A port.

Record the value for that trench on a table like the one shown below in Figure 7 and mark/label that cable.

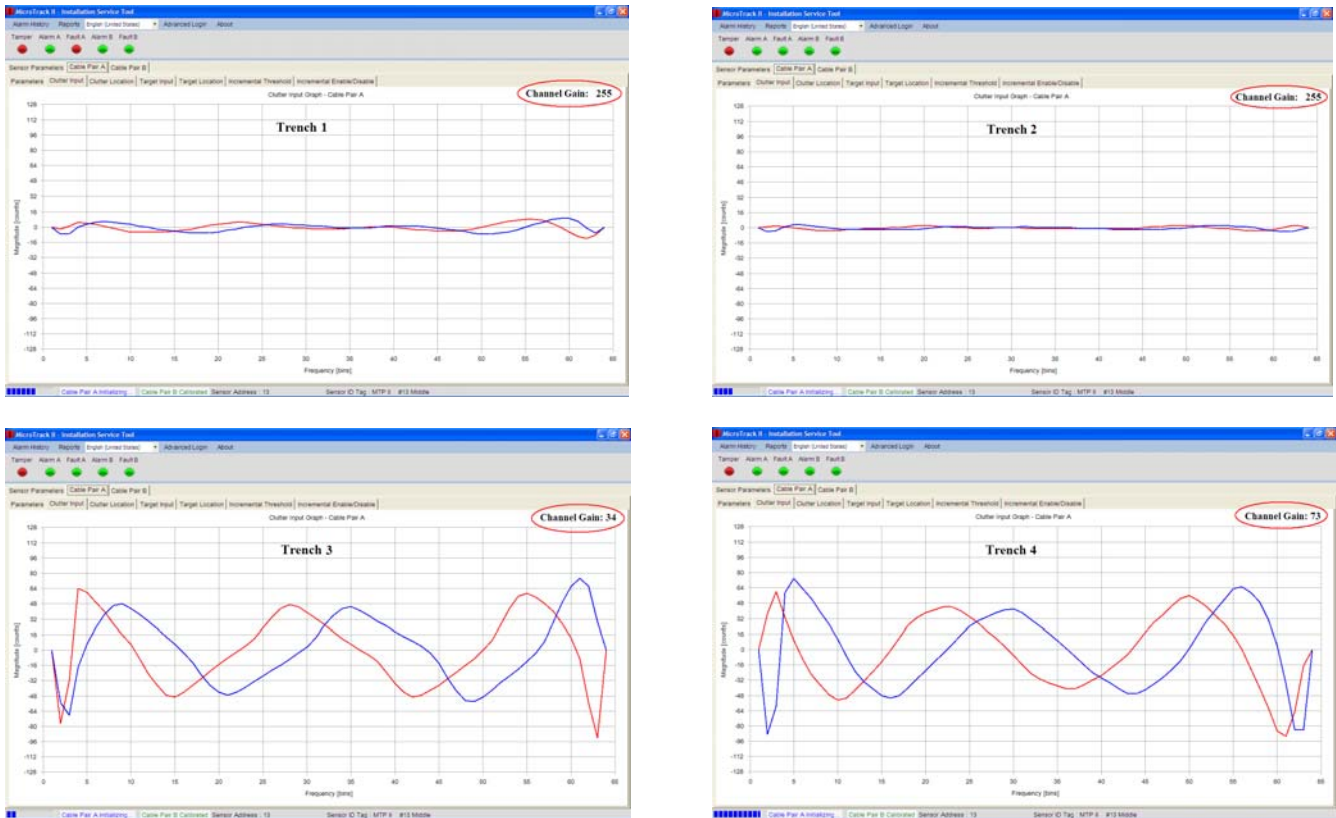

Figure 6

Trench #	Channel Gain
1	255
2	255
3	34
4	73

<< lowest gain

Figure 7

6. Referencing drawings 1 and 2, let's assume that the test cable is lying over the trench marked "3" and this is the one with the LOWEST AGC value. Cable 3 is identified as "Cable B Transmit" in the drawing, so mark the cable that is currently connected to the MTPs TX A port as "Cable B – Transmit".
7. Disconnect the newly marked lead-in cable from the TX A port of the MTP II and connect one of the remaining, unmarked lead-in cables to TX A. Repeat steps 5 and 6 to identify the cable that is now connected to TX A. Mark this cable with the proper label. Repeat this step until all four cables are identified.
8. Once all cables are identified and marked, connect all four cables to their proper ports on the MTP II. Power down this MTP II and move on to the next one and repeat the above procedure.
9. Once all MTP II's have been properly marked and connected, apply power to the system. All MTP II's must now be reconfigured according to the installation manual.